

vsat

Introduction

- VSAT = Very Small Aperture Terminal
- Early Earth Stations in commercial systems were very large and expensive (30 m).
- Need to make system more affordable to end user:
 - Increased transmit power from satellite.
 - Higher frequencies
- Result: Smaller ES antenna size required.

Large Antenna Systems

- Breakpoint between “large” and “small” antennas is at about 100 wavelengths.
- Above breakpoint, “back-fed” configurations such as Cassegrain or Gregorian are economically and technically viable (subreflectors need to be at least 10 wavelengths).
- Below breakpoint, terminals called Small Aperture Terminals.
- Smaller Antennas → Tighter Link Budgets

Cassegrain, gregorian and vsat



Typical Antenna Sizes

- **At C-band: below 5 meters (100 wavelength at 6 GHz).**

- **Extrapolation of terminology:**

USAT = Ultra Small Aperture Terminal.

- **Standard VSAT antennas**
- **Smaller antennas are also included in the concept of VSAT or USAT (DTH, MSS, etc).**

USAT

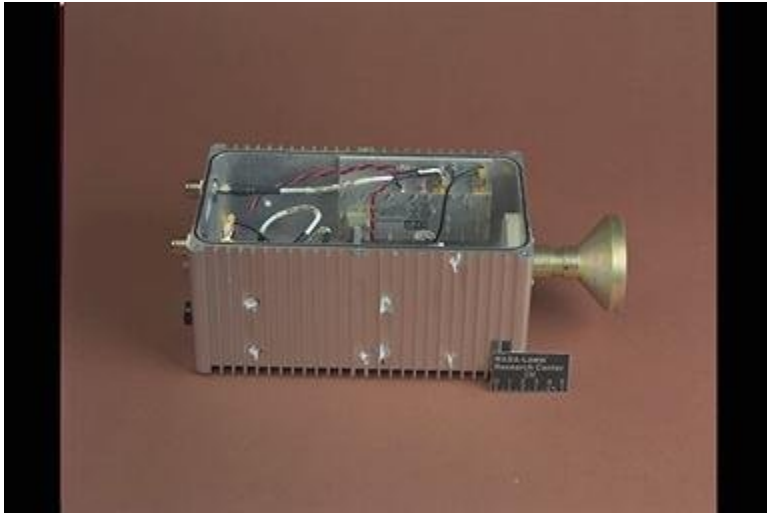

Applications

VSAT SYSTEMS

- **Underlying objective of VSAT Systems: bring the service directly to the end-user**
- **Major reasons for doing this**
 - Reduce hierarchical distribution network (make more efficient and faster - e.g. POS credit)
 - Reduce distribution costs
 - “Leapfrog” technology in developing countries (e.g. VSAT/WLL)

Point of Service



What is a wireless local loop?

- **In a telephone network, a wireless local loop (WLL) is a generic term for an access system that uses a wireless link to connect subscribers to their local exchange in place of conventional copper cable. Using a wireless link shortens the construction period and also reduces installation and operating costs.**

VSAT/WLL

- **Telecommunications and roads are the two major economic growth requirements for developing countries**
- **Major telecommunications infrastructure does not exist in many developing countries**
- **SOLUTION**
 - **Distribute links to communities by satellite/VSAT**
 - **Use Wireless Local Loop from the VSAT**

VSAT/WLL

- **The geostationary satellite is used to link a large number of VSATs with the main switching center in a large city.**
- **Each VSAT acts as the link to the local switching center in the village or rural community, with the final mile of the telephony link being carried over a Wireless Local Loop.**

VSAT/WLL

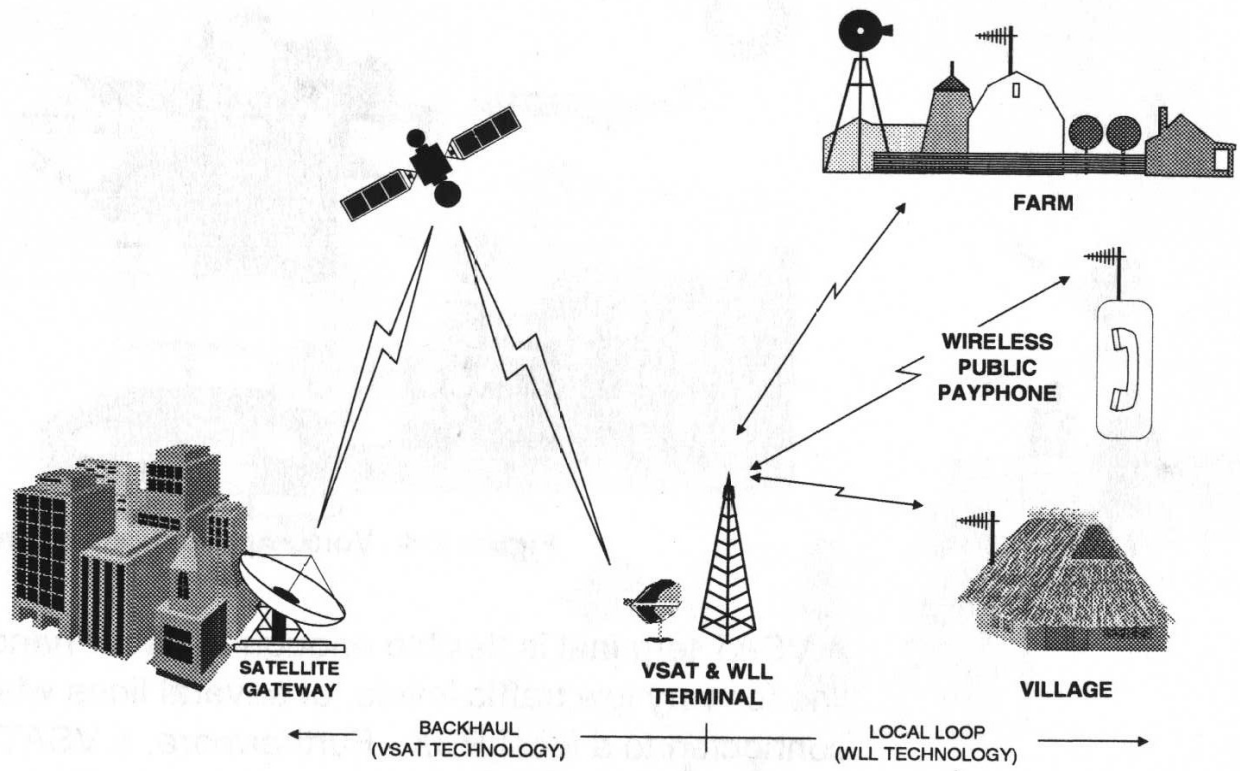

VSAT/WLL User density **dependency**

- **Economic advantages of VSAT/WLL solution depends primarily on user density.**
- **Physical distances, major transportation routes, and geographic barriers, as well as the individual country's demographics and political influences, can alter the breakpoints.**

Motivation to use VSAT/WLL

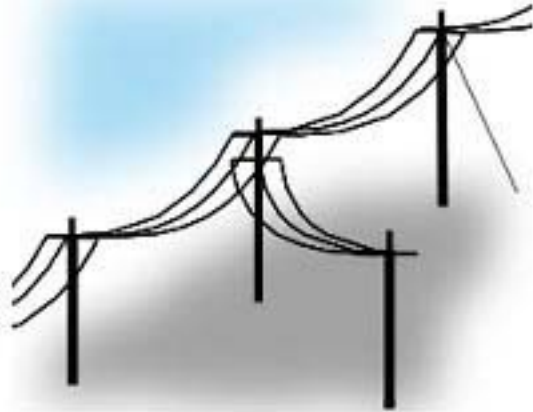

VS



- **The last mile problem**
- **Hard to reach areas**
- **Reliability**
- **Time to deploy (4-6 months vs. 4-6 weeks)**
- **Flexibility**
- **Cost**

VSAT/WLL User density dependency

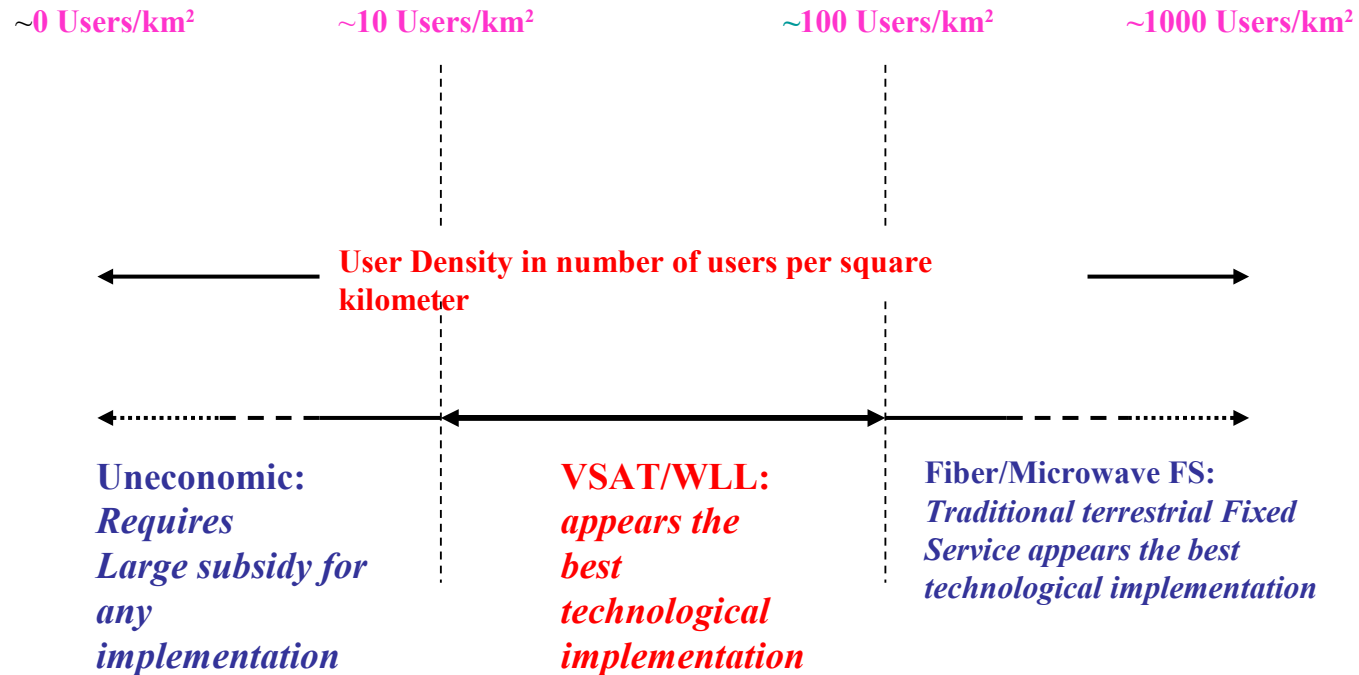

Approximate economic break-points in the implementation choices for serving new regions with different population densities.

Implementations

VSAT IMPLEMENTATION

- There are **three ways** VSAT services might be implemented
 - **One-Way** (e.g. TV Broadcasting satellites)
 - **Split-Two-Way (Split IP) Implementation** (return link from user is not via the satellite; e.g. DirecTV)
 - **Two-Way Implementation** (up- and down-link)

We will be looking at Two-Way Implementation only

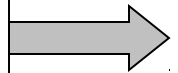

VSAT IMPLEMENTATION

- There are basically two ways to implement a VSAT Architecture
- **STAR**
 - VSATs are linked via a HUB
- **MESH**
 - Each VSAT is capable of communicating directly with any other VSAT. Network control and duties of hub can be carried over by any of the VSAT or master control station duties are shared among the VSATs.

VSAT IMPLEMENTATION

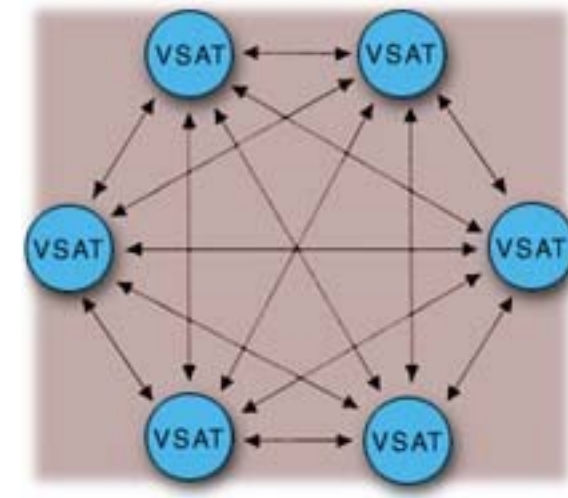
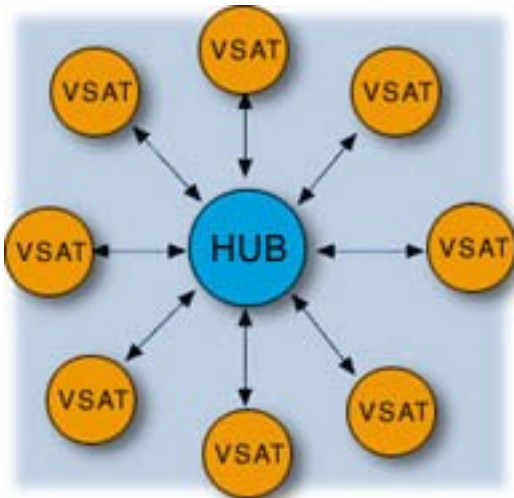

Higher Propagation delay
Used by TDMA VSATs
High central hub investment
Smaller VSAT antenna sizes (1.8 m typically)
Lower VSAT costs
Ideally suited for interactive data applications
Large organizations, like banks, with centralized data processing requirements

Lower Propagation delay (250 ms)
Used by PAMA/DAMA VSATs
Lower central hub investment
larger VSAT antenna sizes (3.8 m typically)
Higher VSAT costs
Suited for high data traffic
Telephony applications and point-to-point high-speed links

VSAT STAR ARCHITECTURE

- In this network architecture, all of the traffic is routed via the master control station, or Hub.
- If a VSAT wishes to communicate with another VSAT, they have to go via the hub, thus necessitating a “double hop” link via the satellite.
- Since all of the traffic radiates at one time or another from the Hub, this architecture is referred to as a STAR network.

VSAT STAR ARCHITECTURE

**All communications to
and from each VSAT is
via the Master Control
Station or Hub**

Master Control Station
(The Hub)

VSAT
Community

VSAT STAR ARCHITECTURE

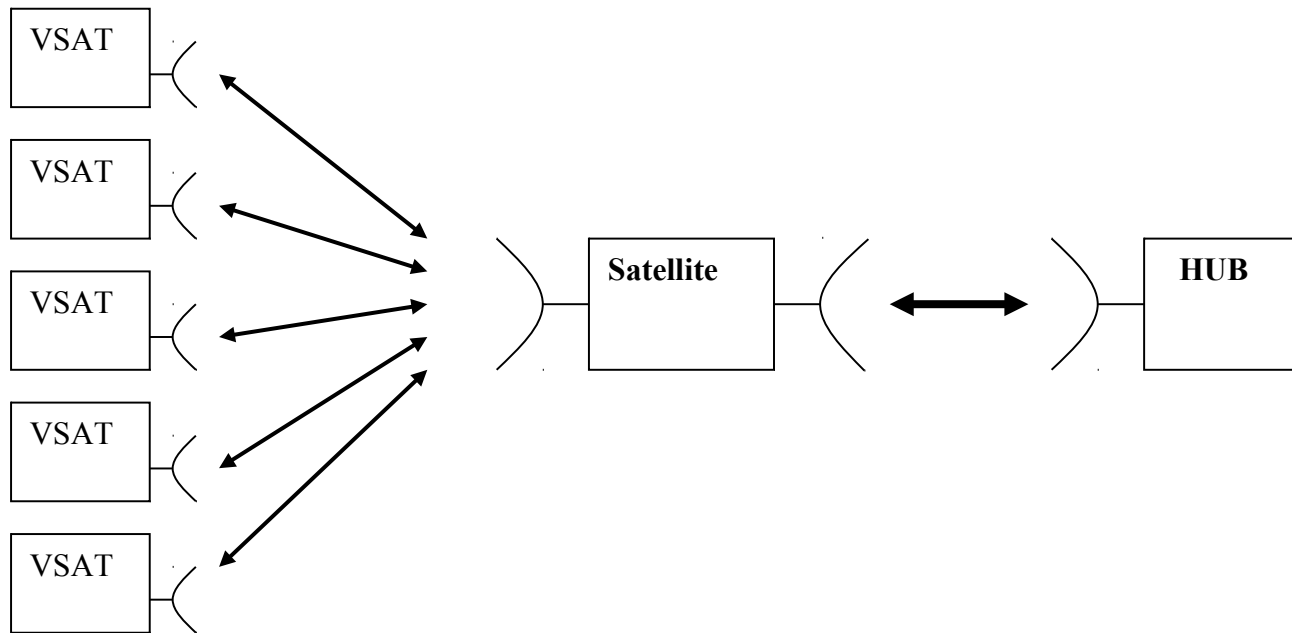

Topology of a STAR VSAT network viewed from the satellite's perspective

Note how the VSAT communications links are routed via the satellite to the Hub in all cases.

VSAT MESH ARCHITECTURE

- In this network architecture, each of the VSATs has the ability to communicate directly with any of the other VSATs.
- Since the traffic can go to or from any VSAT, this architecture is referred to as a MESH network.
- It will still be necessary to have network control and the duties of the hub can either be handled by one of the VSATs or the master control station functions can be shared amongst the VSATs.

VSAT MESH ARCHITECTURE

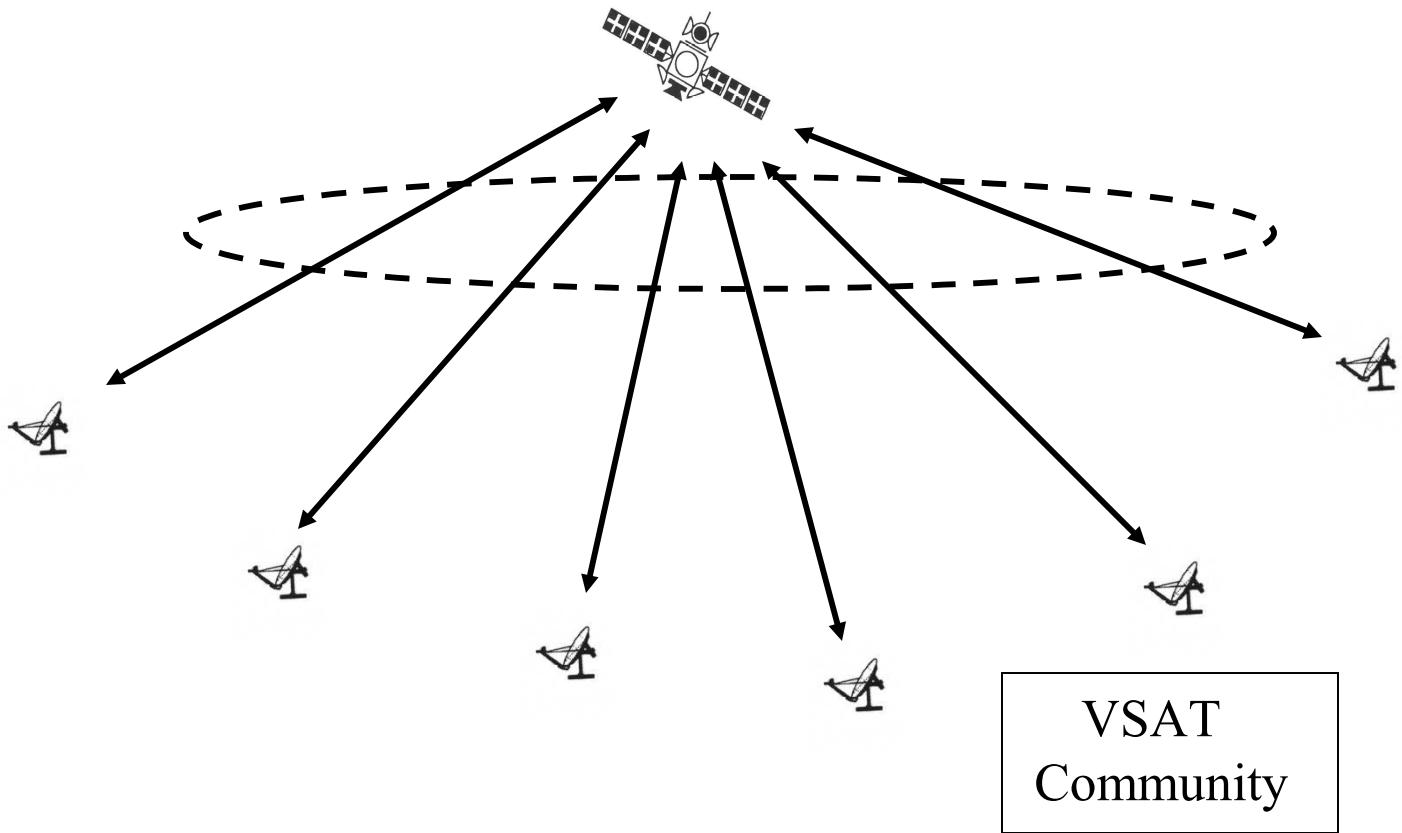

VSAT MESH ARCHITECTURE

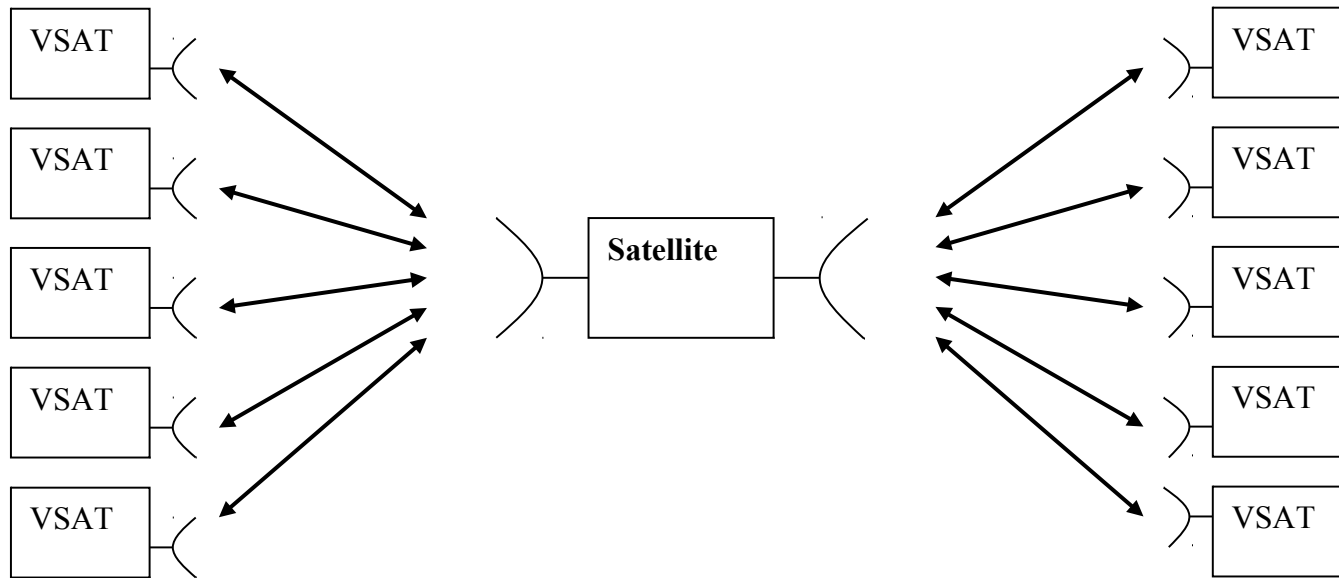

**Topology of a MESH VSAT network from the satellite's perspective
Note how all of the VSATs communicate directly to each other via the
satellite without passing through a larger master control station
(Hub).**

ADVANTAGES OF STAR

- **Small uplink EIRP of VSAT (which can be a hand-held telephone unit) compensated for by large G/T of the Hub earth station**
- **Small downlink G/T of user terminal compensated for by large EIRP of Hub earth station**
- **Can be very efficient when user occupancy is low on a per-unit-time basis**

(EIRP)

- In radio communication systems, **Equivalent isotropically radiated power (EIRP)** or, alternatively, **Effective isotropically radiated power** is the amount of power that a theoretical isotropic antenna (which evenly distributes power in all directions) would emit to produce the peak power density observed in the direction of maximum antenna gain

G/T (Gain to System Noise Temperature)

- **antenna gain-to-noise-temperature (G/T):** In the characterization of antenna performance, a figure of merit, where G is the antenna gain in decibels at the receive frequency, and T is the equivalent noise temperature of the receiving system in kelvins.

DISADVANTAGES OF STAR

- **VSAT terminals cannot communicate directly with each other; they have to go through the hub**
- **VSAT-to-VSAT communications are necessarily double-hop.**
- **GEO STAR networks requiring double-hops may not meet user requirements from a delay perspective**

ADVANTAGES OF MESH

- **Users can communicate directly with each other without being routed via a Hub earth station**
- **VSAT-to-VSAT communications are single-hop**
- **GEO MESH networks can be made to meet user requirements from a delay perspective**

DISADVANTAGES OF MESH

- **Low EIRP and G/T of user terminals causes relatively low transponder occupancy**
- **With many potential user-to-user connections required, the switching requirements in the transponder will almost certainly require On-Board Processing (OBP) to be employed**
- **OBP is expensive in terms of payload mass and power requirements**

How a VSAT can cause interference to other satellite systems

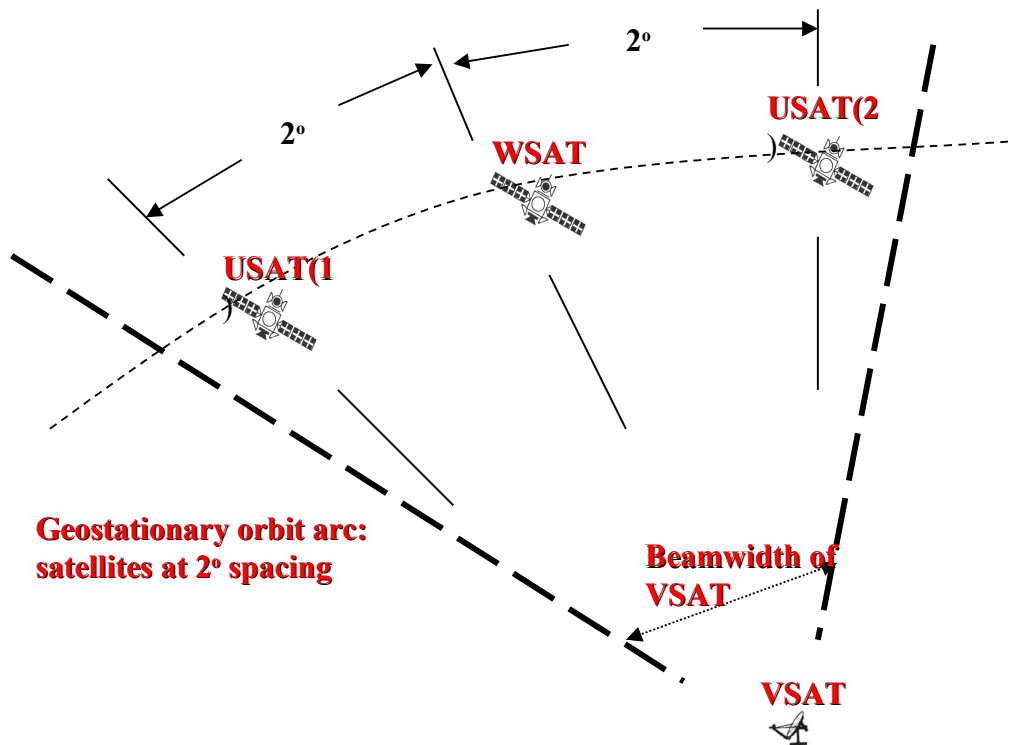

- In this example, the VSAT is transmitting to a wanted satellite (WSAT) but, because the antenna of the VSAT is small, its beam will illuminate two other adjacent, unwanted satellites (USATs) that are 2° away in the geostationary arc.

- In a like manner, signals from USAT (1) and USAT(2) can be received by the VSAT, thus causing the potential for interference if the frequencies and polarizations used are the same.

Interference Scenario

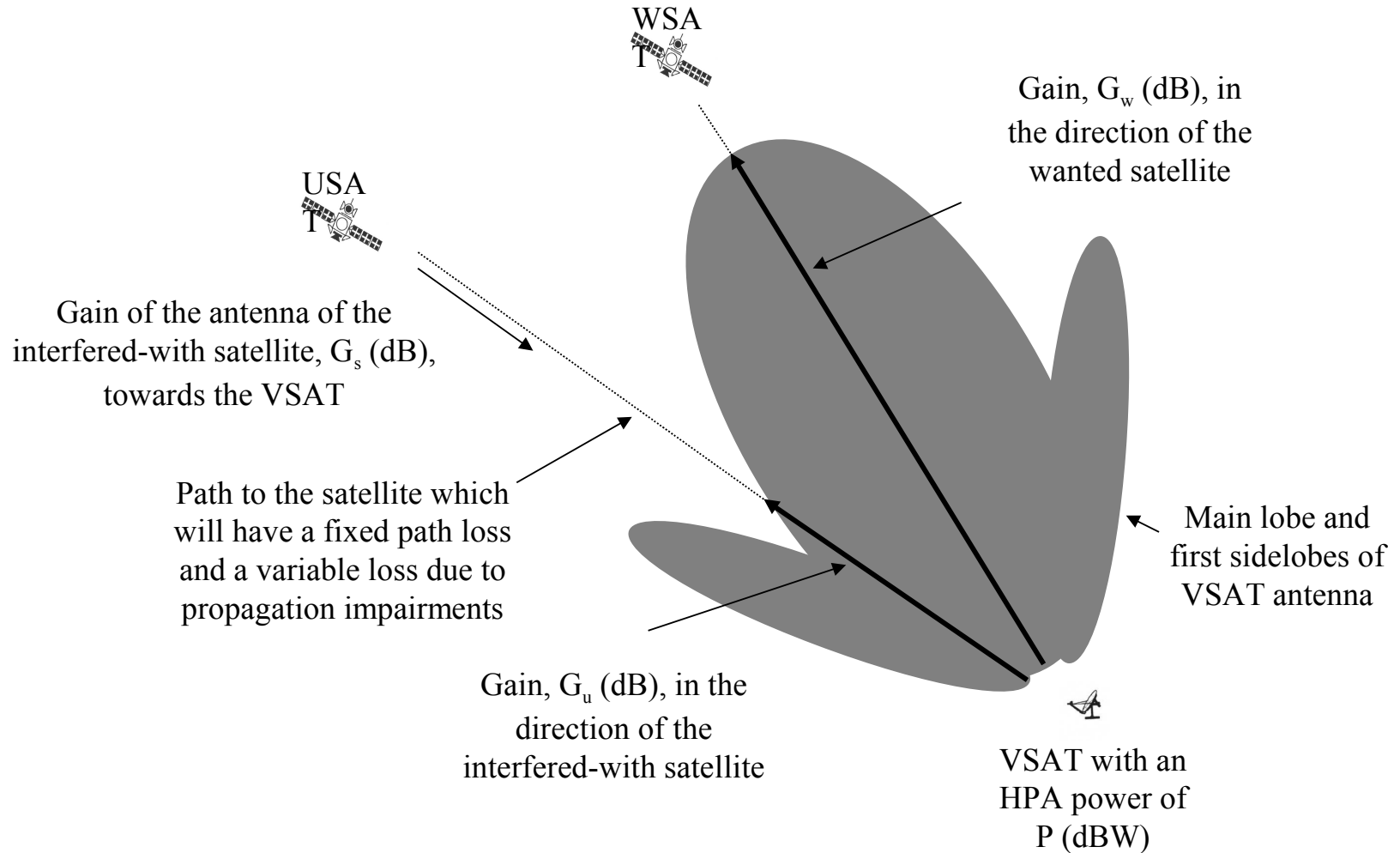

Interference Scenario

- **The EIRP of the VSAT towards the interfered-with satellite $[P(\text{dBW}) + G_u(\text{dB})]$ is the interference power from the VSAT into the interfered-with satellite.**
- **To develop the interference link budget, the Gain of the interfered-with satellite in the direction of the VSAT, $G_s(\text{dB})$, would be used, plus any additional effects along the path (such as site shielding, if used, expected rain effects for given time percentages, etc.)**

Coding and Modulation

Modulation Scheme:

- **High index modulation schemes use bandwidth more effectively.**
- **High index modulation schemes also require more link margin, more amplifier linearity.**
- **They are also more susceptible to interference and harder to implement.**
- **Typically systems work with BPSK or QPSK.**

Coding Scheme:

- **Inner code,**
- **Outer interleaving code (Reed-Solomon) to protect against burstiness.**

Earth Stations

VSAT Earth Station

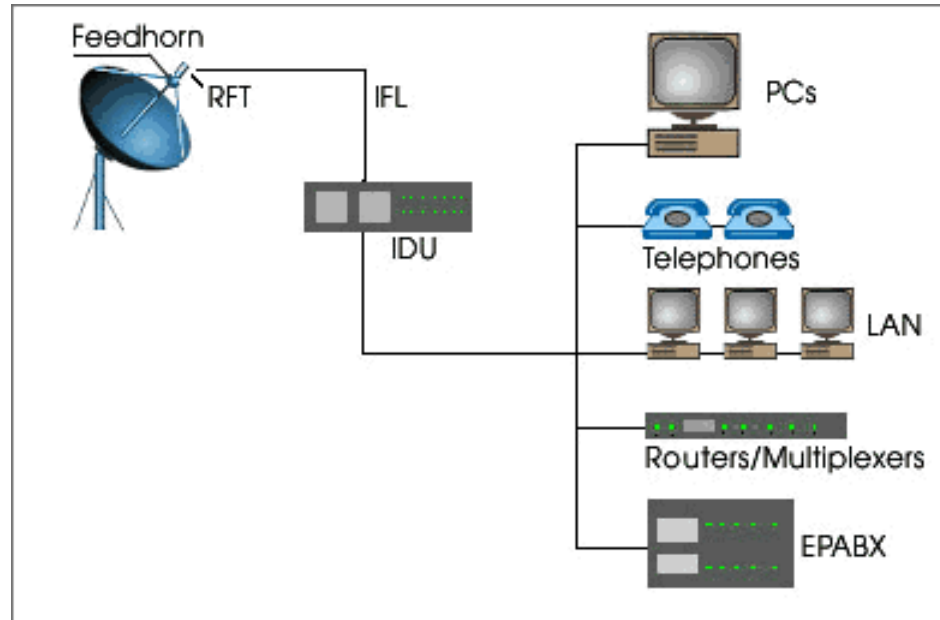

- **Outdoor Unit (ODU)**
- **Inter-facility link (IFL)**
- **Indoor Unit (IDU)**

VSAT Earth Station

- **The VSAT Outdoor Unit (ODU) is located where it will have a clear line of sight to the satellite and is free from casual blockage by people and/or equipment moving in front of it. It includes the Radio Frequency Traseiver (RFT).**
- **The Inter Facility Link (IFL) carries the electronic signal between the ODU and the Indoor Unit (IDU) as well as power cables for the ODU and control signals from the IDU.**
- **The IDU is normally housed in a desktop computer at the User's workstation and consists of the baseband processor units and interface equipment (e.g. computer screen and keyboard). The IDU will also house the modem and multiplexer/demultilexer (mux/demux) units if these are not already housed in the ODU.**

VSAT Earth Station - Block Diagram

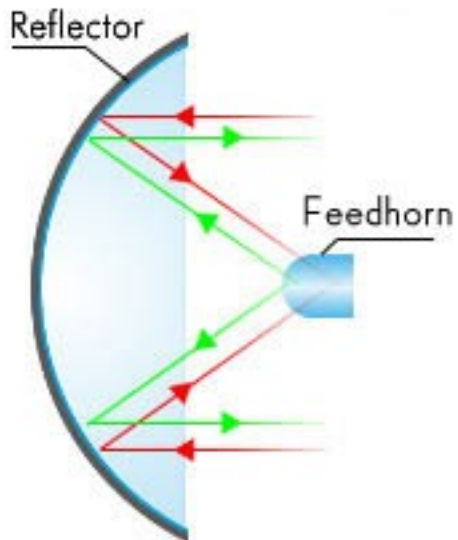
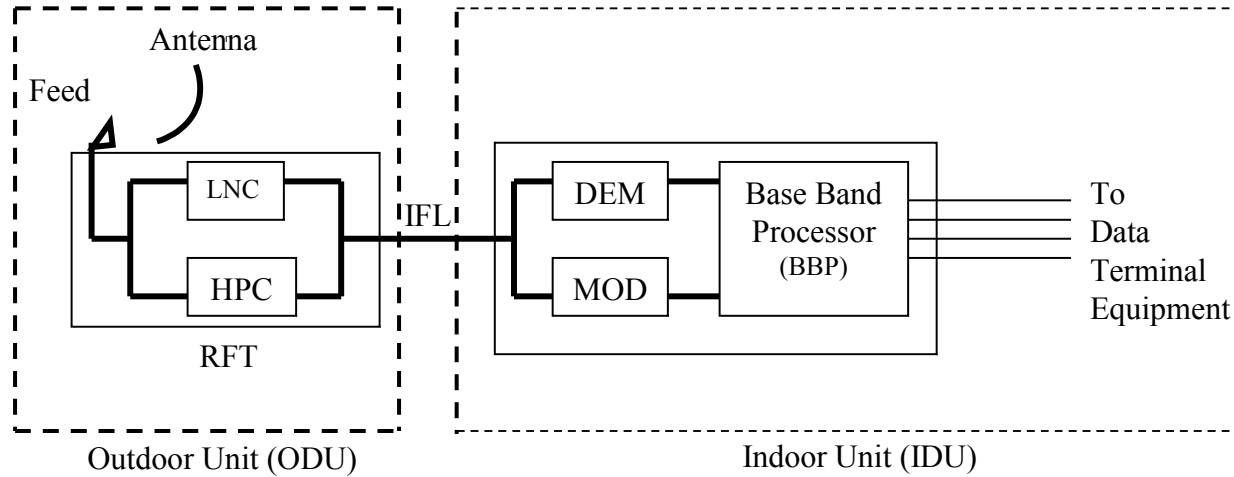

RFT



IFL

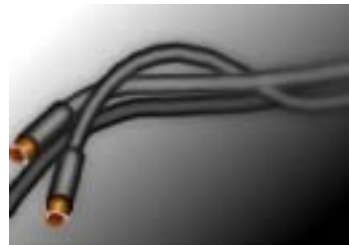

IDU



VSAT Earth Station – Blocks

Description

- **The Low Noise Converter (LNC) takes the received RF signal and, after amplification, mixes it down to IF for passing over the inter facility link (IFL) to the IDU.**
- **In the IDU, the demodulator extracts the information signal from the carrier and passes it at base band to the Base Band Processor.**
- **The data terminal equipment then provides the application layer for the user to interact with the information input. On the transmit operation, the user inputs data via the terminal equipment to the baseband processor and from there to the modulator.**
- **The modulator places the information on a carrier at IF and this is sent via the inter facility link to the High Power Converter (HPC) for upconversion to RF, amplification, and transmission via the antenna to the satellite.**